

Pulse Width Modulation (PWM) and Relays

Introduction

Efficient energy management is one of the main goals in automotive industry. Regulating actuators by Pulse Width Modulation (PWM) is a widespread means of improving efficiency. There has been an increasing penetration of PWM controlled applications like heater blowers, lamps, EPAS. Once a PWM controller is available in the car it could be used for several applications.

Heat dissipation of monostable relay coils is one source of high temperatures in relay boxes, distribution and switching modules. That limits not only the relay performance, but the performance of the whole unit, too. These heat sources could be removed by using latching relays or at least be reduced by use of high resistive coils and / or by applying PWM controlled driver circuits. This application note summarizes key aspects, which have to be taken into account when using PWM strategy for the relay coil driver.

Relay status

The best way to regulate the relay coil power consumption would be a DC current driver, since the main electrical parameters of a relay (pull-in, pull-through and holding currents) are to a certain extent temperature independent. But relay coils are usually voltage driven. Thus those characteristics translate into the temperature dependent voltages for pull-in, pull-through and holding. The reason is the temperature depending resistance of the coil wire material, i.e. copper.

Once the relay has pulled through, it keeps its status (armature keeps to its position on the core) unless the coil current falls below the holding current. For shock and vibration resistance there is an additional excess current required, which depends on the relay type, further relay parameters and shock and vibration requirements.

PWM controlled drivers regulate the effective applied voltage by changing the duty ratio of DC voltage normally at a given frequency. Inductive systems like relay coils respond in presence of parallel components to a negative going edge with a current decrease.

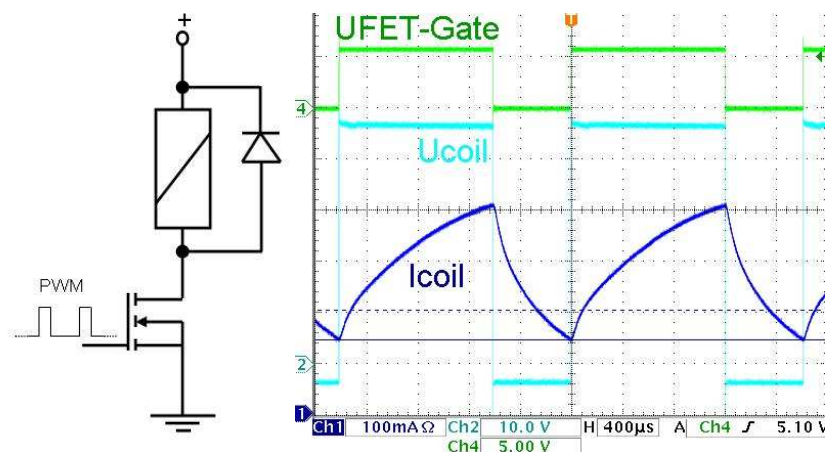

Figure 1: Current response to PWM voltage step with parallel diode

This ripple around the effective current depends on the coil inductance, coil suppression, PWM frequency, voltage level and duty ratio.

It is always recommended to start with 100% PWM duty ratio until the relay pulls-through and settles. The necessary time depends on excess voltage, relay type, etc..., but 500ms should be sufficient. Otherwise it will take some time for the relay current to settle around the effective current.

In order to warrant a good relay performance with PWM it has to be made sure, that under all circumstances the coil current does not undercut the level of holding current plus the excess current for shock and vibration. Otherwise the armature and the contacts might open. Then the relay has to pull-in and pull-through again to settle.

Repeated opening and closing the armature might cause humming noise.

Unintended opening and closing the armature and contacts under load might cause contact welding.

Inductance

Relay coil inductances are in general relatively high, which result in comparatively small current ripples. But these values are not constant and vary strongly within one relay family or one type. The relay coil inductance depends among others on quite a few parameters, which are not under focus in a standard relay manufacturing process. Furthermore it heavily depends on the coil current (saturation) and status of the relay (armature open or closed).

Coil suppression

In DC coil drivers coil suppression is done for protecting the relay driver from high coil switch-off voltage peaks. There are several options for this (see figure 2). For PWM coil drivers suppression is even more crucial, since the coil switch off occurs at PWM frequencies, i.e. up to several thousand times per second.

Furthermore coil suppression reduces the ripple coil current, and thus the potential for dropping out since the coil current takes longer to decrease. Therefore from this perspective the stronger the suppression the better, i.e. best with parallel diode (red circle in figure 2). On the other hand this case is exactly the worst for relay switching capability. For single drivers the best compromise is probably an anti parallel low voltage (3...9V) Z-diode (blue circle in figure 2). A Zener diode in parallel to the driver would cause a varying voltage clamp across the relay coil during switch-off due to varying supply voltage.

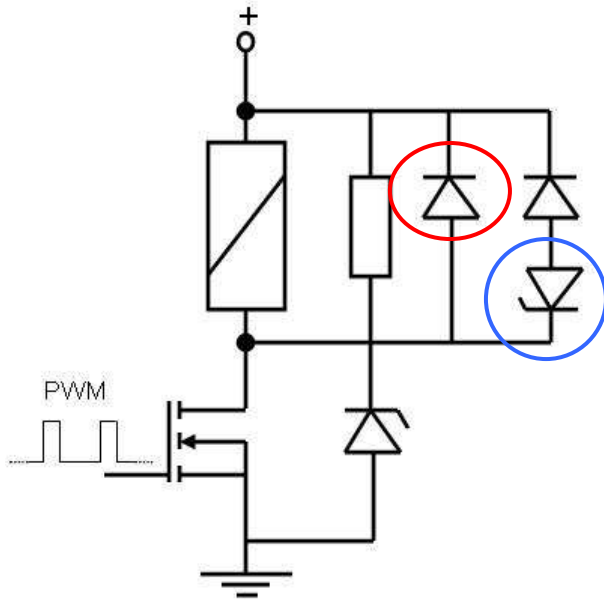

Figure 2: Relay coil low side driver with coil suppression options

Frequency:

As could be seen in figure 3 the higher the frequency the lower is the ripple current. Therefore the effective coil voltage could be chosen to be lower with keeping all the other parameters constant.

We recommend a PWM frequency of minimum 20kHz.

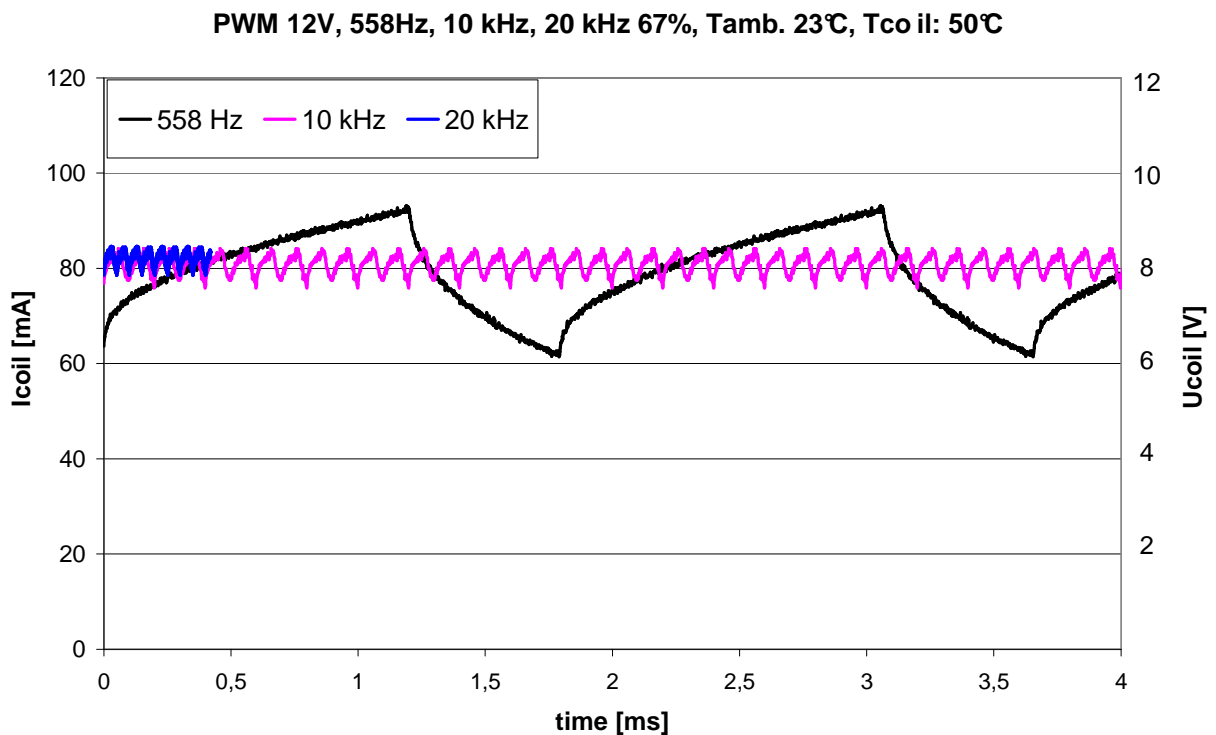

Figure 3: Effect of different PWM frequencies on ripple coil current on Power F relay with parallel diode

Duty Ratio

The effective coil voltage is the product of PWM duty ratio and supply voltage. However the supply voltage varies due to changes in system load (e.g. cranking) and alternator and battery status. Therefore the PWM duty ratio should be regulated according to the supply voltage. A tight regulation would be optimal for efficiency. But slight variation on the supply side would cause a continuous regulation of the PWM duty ratio. Furthermore regulation response time would need to be faster than 1ms to ensure, that the effective coil voltage does not undercut the required voltage limit.

Figures 4 and 5 show a PWM concept for a requirement of 8V effective coil voltage using a duty ratio regulation with 2V steps of the supply voltage.

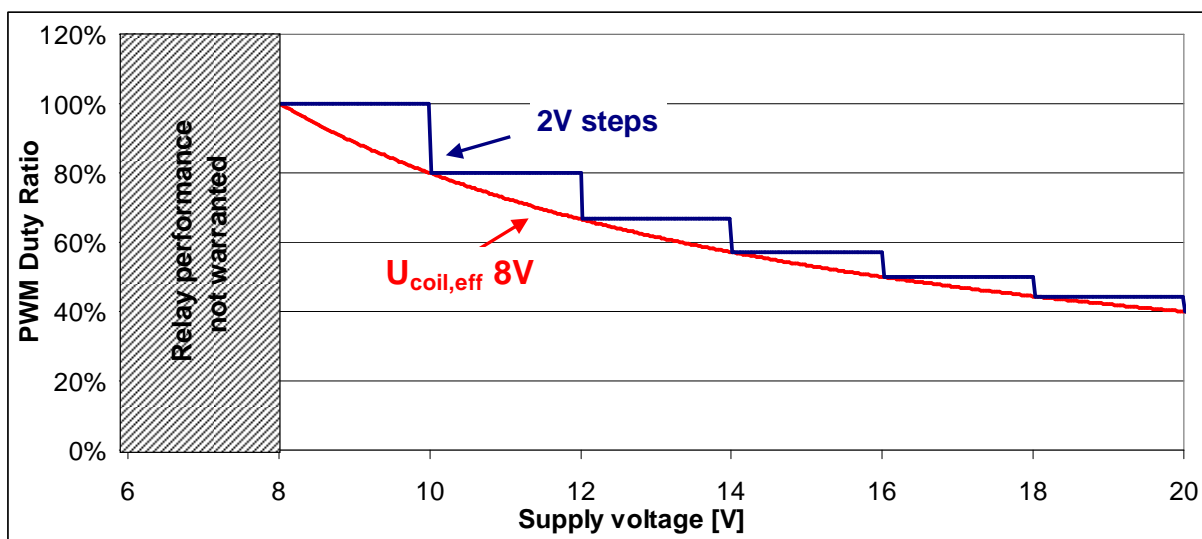

Figure 4: PWM duty ratio as a function of supply voltage with 2V step regulation

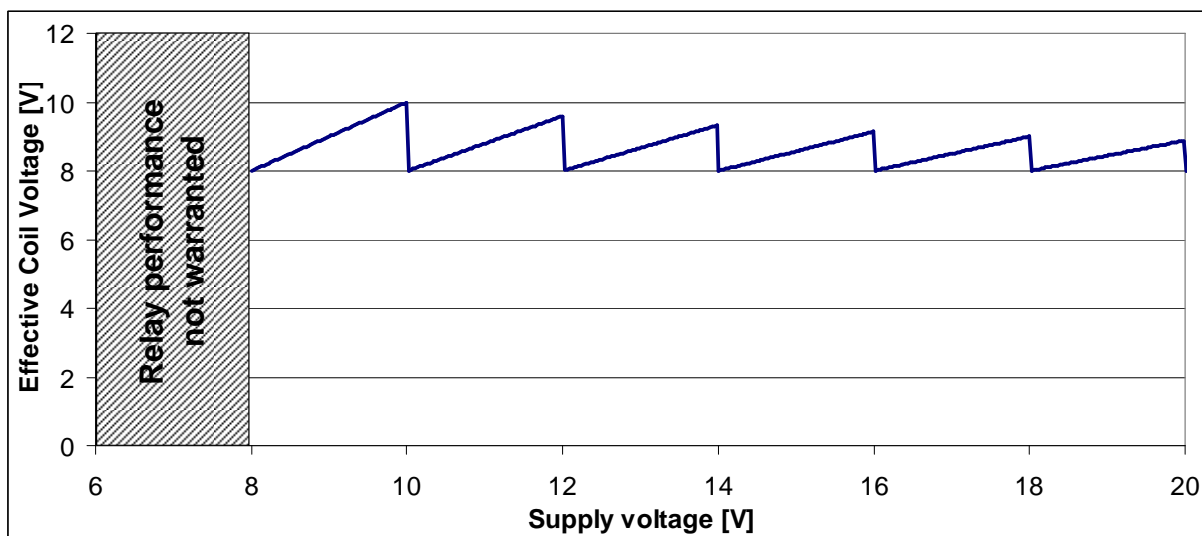

Figure 5: Effective coil voltage as function of supply voltage with 2V step regulation

Disturbing Noises

The application of PWM voltage across the relay coil causes magnetostriction of the iron within the relay magnetic system (core/frame/armature). The result is a slight audible noise if the relay was freely suspended. However when the relay soldered or welded onto a rigid lead frame that noise might be amplified. This depends on the lead frame (suspension, dimension, etc.) and the sound propagation and damping within the car. Choosing 20 kHz PWM avoids disturbing noises for human beings but might cause problems to animals.

EMC (Electromagnetic compatibility)

Due to the steep voltage and current edges EMC problems are possible. Therefore electromagnetic compatibility tests of the whole unit are necessary.